

Masse de la table élévatrice ≈ 350 Kg
Charge = 1500 Kg

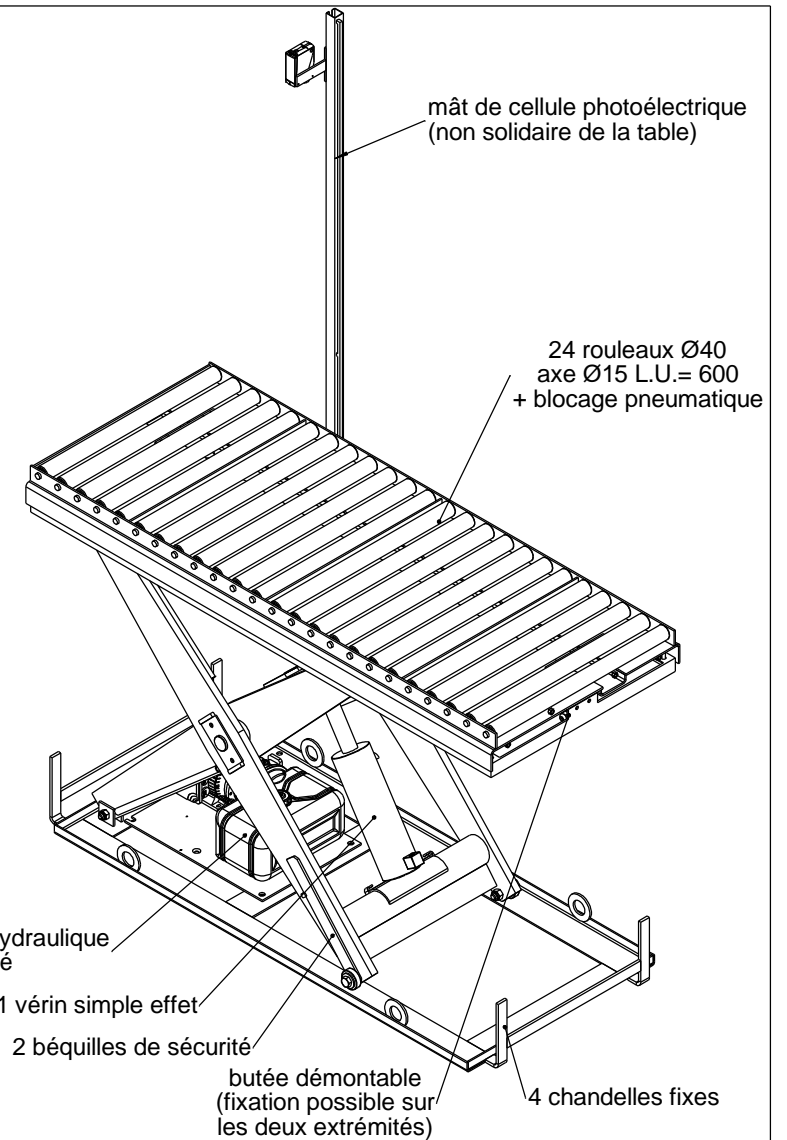
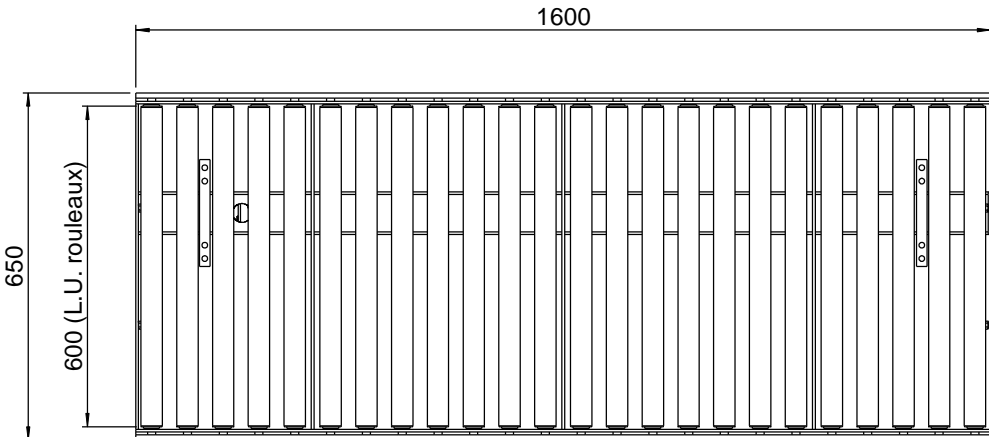
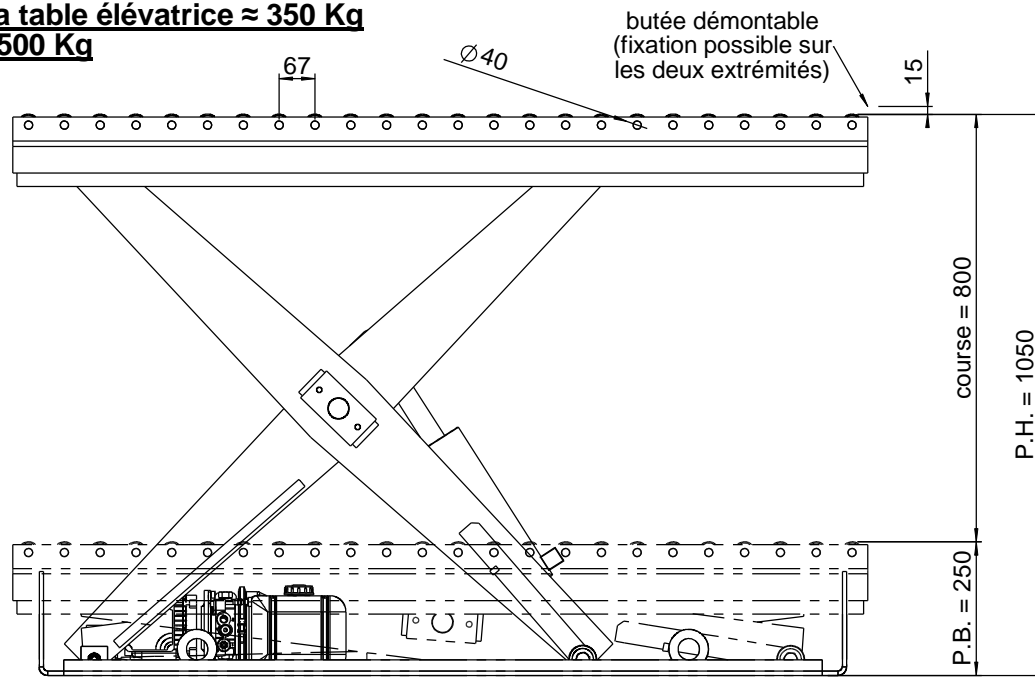

Modifications	Ind.	Date	Nature de la modification	Visa
04				
03				
02				
01				

INTERLIFT Z.A.C. de Jailly - B.P.28 Tél : 03-87-51-58-58/Fax : 03-87-51-90-48
CONSTRUCTEUR 57535 MARANGE-SILVANGE e-mail : interlift.be@wanadoo.fr

A3 Echelle 1:10

Dessiné par : H-D

Le 29/10/2007 N° Dessin : 8144-B-1007-01 Client :

P15/100 (1600x650)
Plan d'ensemble